

OFF ROAD PERFORMANCE

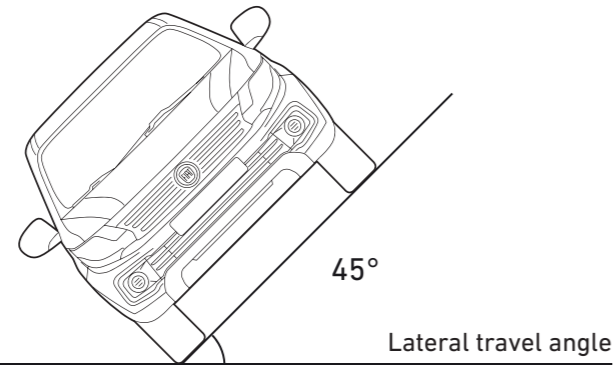
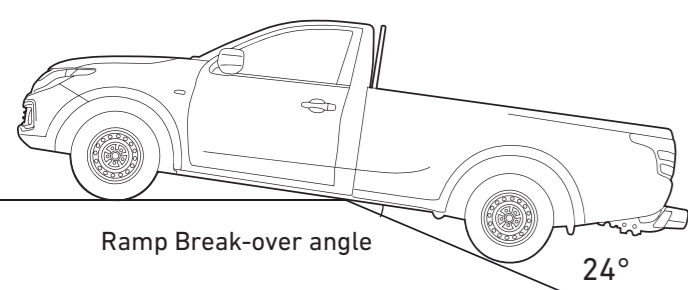
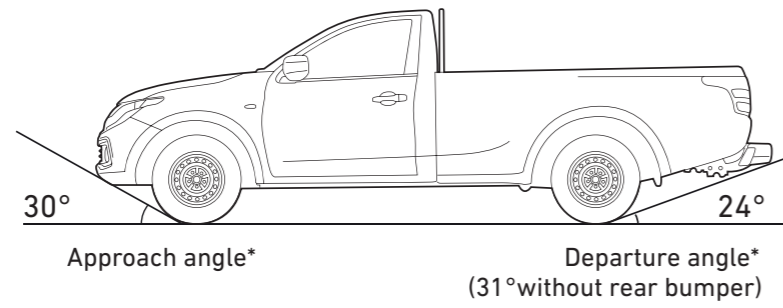

SINGLE CAB

*4x4 & 4x2 High ride

OFF ROAD PERFORMANCE

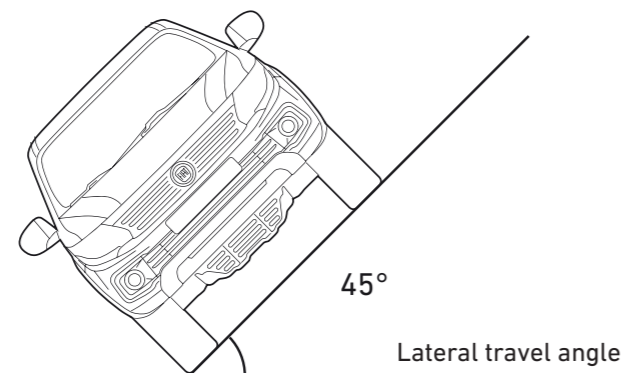
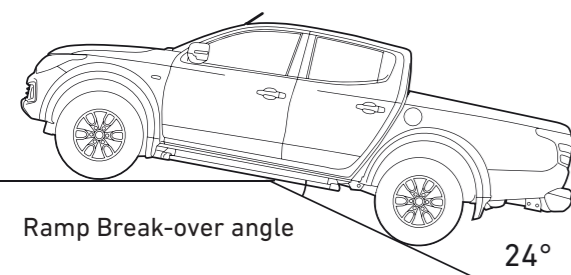
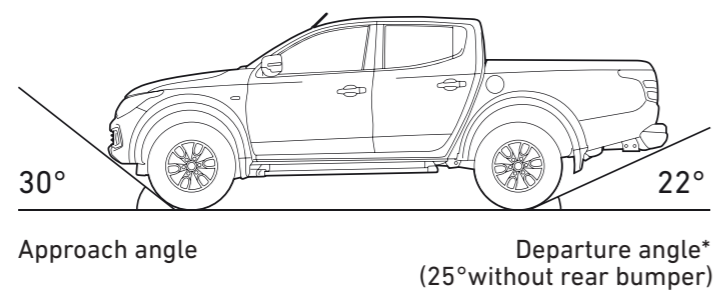

DOUBLE CAB

*4x4 & 4x2 High ride

NEW FULLBACK



NEW FULLBACK



IT SHOULDERS EVERYTHING. EVEN YOUR **BIG** DREAMS.

Now you can make your dreams a reality with someone to share the load. It's the **new Fullback**, an urban and off-road work vehicle that's rewriting the rules of versatility. It combines rugged looks with an outstanding drag coefficient (0.40). And with a turning radius of just 5.7 m (2WD) or 5.9 m (4WD), the **new Fullback** not only carries everything, it's a breeze to manoeuvre and park too. So wherever you go, from city traffic to a windswept work site, it'll get you there.

NEW FULLBACK



The new Fullback comes in 3 versions - single cab, double cab and chassis-cab - so it covers all your needs. And with its spacious, reinforced cargo bed, it'll stand up to the heaviest loads.

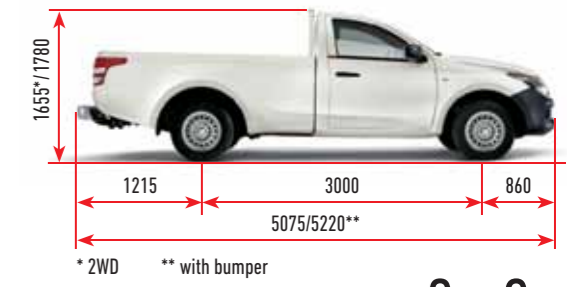

Single Cab

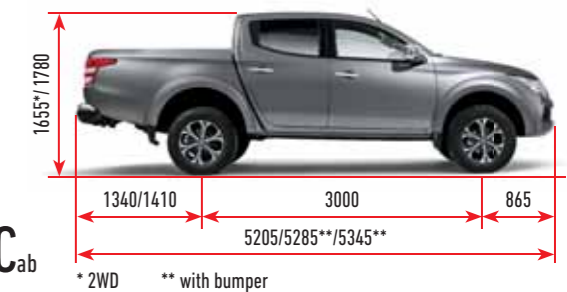

Double Cab



Single Cab



Double Cab

**THE
BIGGER
THE LOAD,
THE EASIER THE SUCCESS.**

You can count on the new Fullback any time, anywhere. Measuring 5.2 m long by 1.8 m wide. The **new Fullback** has a powerful, muscular look. But its key strength is its payload, of up to 1,000 kg.

NEW FULLBACK



**IT GIVES
YOUR
CHALLENGES
A HUGE SPACE.**

The new Fullback won't let you down, however tough the job is. But it's also got your comfort covered too. Its spacious and stylish interior is soundproofed, so you won't be distracted by noise or vibration. With supportive seats, optimised driving position, five upholstery options (including leather), three dashboard styles (one for each trim) and automatic dual-zone air conditioning, it's got all the comforts of a car. And if that's not enough, the smart infotainment system gives you everything you need to tackle your day in style.



NEW FULLBACK



If you want a relaxed ride without compromising on performance, why not go for the 5-speed automatic, which lets you change gear with a simple lever movement? Just slip it into 'Drive' and away you go.



Five-speed automatic gearbox

And with the exclusive 4WD* electronic selector you can go anywhere, at any speed, in 4-wheel drive. So when the going gets tough, just turn the differential knob and send maximum torque to each wheel. Job done.



* only for automatic transmission



Five-speed manual gearbox for the 4WD version

A GREAT BOOST TO HAVE A GREAT DAY AT WORK.

When there's work to be done. The new Fullback ready for anything and totally unstoppable.

The new Fullback's range of powerful, reliable engines includes:

- a 2.5-litre diesel with 81 to 131 kW of power on tap, and a five-speed manual or automatic gearbox;
- a 2.4-litre 97 kW petrol with five-speed manual gearbox.

But the new Fullback's not all about power, it's about protection too. So depending on trim, it comes with driver and passenger airbags and a range of safety systems, such as ESP with Hill Assist which makes the uphill departures easier, bi-xenon headlights, LED daytime running lights, rear view camera and cruise control.



S

Standard*

Drive system: 4x2 or 4x4
 Suspension: Heavy Duty Suspension
 Exterior: Black front bumper
 Rear cromed bumper (opt)
 Cargo bed outer hooks (opt)
 Headlights: Halogen with black bezel
 Windows: Manual
 Air Conditioning (opt): Manual

* version available: single cab and double cab



T

RIM LEVELS



L

Drive system: 4x2 High ride & 4x4 electronic selector
 Suspension: Touring suspension
 Interior: Floor console with armrest
 Exterior: Chrome accents and body-coloured bumper
 Headlights: Halogen with chrome bezel
 Windows: Electric
 Air Conditioning (opt): Automatic
 Alloy wheel (opt): 17"



S

Drive system: 4WD manual selector
 Suspension: Touring suspension
 Interior: Floor console with armrest
 Exterior: Body-coloured front bumper / Cargo bed outer hooks (opt)
 Headlights: Halogen with black bezel
 Windows: Manual
 Air Conditioning (opt): Manual
 Alloy wheel (opt): 16"



NEW FULLBACK

BODY COLOURS

METALLIC



462 GR/Green



463 Blue



480 Titanium Grey



478 Brown



555 Black (Mica)

PASTEL



473 Red



563 White



557 White (Pearl)

Colors may vary by market

NEW FULLBACK

HUB CAPS AND RIMS



15" hub caps



16" alloy rims



16" alloy rims



17" alloy rims



More care for your vehicle

ACCESSORIES BY MOPAR



Italian badge

Cargo bed liner

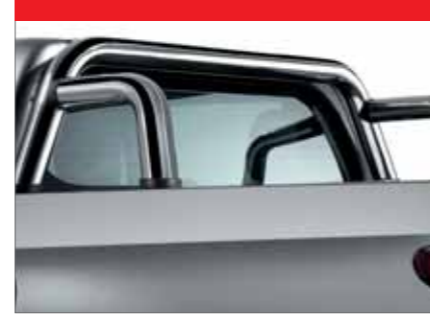
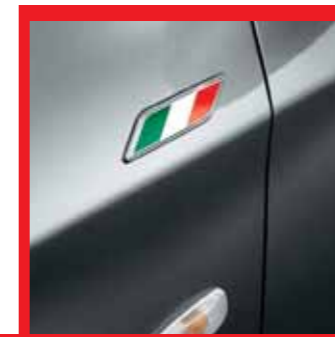

Sport bar



Side door garnish

BODY TYPE	AFRICA LHD								AFRICA RHD					GCC*					
	DOUBLE CAB				SINGLE CAB				DOUBLE CAB			SINGLE CAB		DOUBLE CAB			SINGLE CAB		
MODEL CODE	484	485/488	485 / 488	441	421	141	121	123 / 12C	982	985	9A5	635	630	E85	E80	E20	E20		
TRIM LEVEL	LX		SX	STANDARD	STANDARD	STANDARD			LX			STANDARD		SX			STANDARD		
TRACTION	4WD				2WD				4WD			2WD HIGH-RIDE		2WD		4WD			2WD
Overall Length w/o rear bumper (mm)	5205	5205	5205	5205	5205	5075	5075	5075	5205	5205	5205	5075	5075	5205	5205	5205	5075		
Overall Length w/ rear bumper (mm)	5345	5345	5345	5345	5345	5220	5220	5220	5345	5345	5345	5220	5220	5345	5345	5345	5220		
Width (mm)	1815	1815	1785	1785	1785	1785	1785	1785	1815	1815	1785	1785	1785	1815	1785	1785	1785		
Height (mm)	1780	1780	1780	1780	1765	1655	1655	1655	1780	1780	1775	1655	1655	1780	1780	1780	1655		
Track	FR (mm)	1520	1520	1520	1520	1520	1520	1520	1520	1520	1520	1520	1520	1520	1520	1520	1520		
	RR (mm)	1515	1515	1515	1515	1515	1515	1515	1515	1515	1515	1515	1515	1515	1515	1515	1515		
Overhang w/o rear bumper	FR (mm)	865	865	865	865	865	865	865	865	865	865	865	865	865	865	865	865		
	RR (mm)	1340	1340	1340	1340	1215	1215	1215	1340	1340	1340	1215	1215	1340	1340	1340	1215		
Wheelbase (mm)	3000	3000	3000	3000	3000	3000	3000	3000	3000	3000	3000	3000	3000	3000	3000	3000	3000		
Bed dimensions	Length (mm)	1520	1520	1520	1520	2265	2265	2265	1520	1520	1520	2265	2265	1520	1520	1520	2265		
	Width (mm)	1470	1470	1470	1470	1470	1470	1470	1470	1470	1470	1470	1470	1470	1470	1470	1470		
	Hight (mm)	475	475	475	475	475	475	475	475	475	475	475	475	475	475	475	475		
Kerb weight kg	1830	1820	1805	1775	1590	1660	1500	1505	1835	1820	1705	1505	1410	1805	1685	1510	1410		
Gross vehicle weight kg	2870	2850	2850	2850	2570	2760	2570	2570	2870	2850	2760	2570	2570	2850	2700	2525	2570		
Seating capacity	5	5	5	5	6	3	3	3	5	5	5	3	3	5	5	6	3		
Ground clearance	205	205	200	200	200	200	200	200	205	205	200	200	200	205	200	200	200		
Cargo floor height	850	850	845	845	715	710	710	710	850	850	845	710	710	850	845	845	710		
Departure angle w/o rear bumper	25	25	25	25	25	31	31	31	25	25	25	31	31	25	25	25	31		
Approach angle	30	30	30	30	30	30	30	30	30	30	30	30	30	30	30	30	30		
PERFORMANCE																			
Max Speed km/h	165	167	167	147	147	147	152	165	179	167	167	165	169	167	169	169	169		
ENGINE																			
Emission level	Euro2	Euro2/4	Euro2/4	Euro2	Euro2	Euro2	Euro2	Euro2/4	Euro2	Euro2	Euro2	Euro2	Euro2	Euro2	Euro2	Euro2	Euro2		
Type	Diesel	Diesel	Diesel	Diesel	Diesel	Diesel	Diesel	Diesel	Diesel	Diesel	Diesel	Diesel	Petrol	Diesel		Petrol			
Displacement cc	2477	2477	2477	2477	2477	2477	2477	2477	2477	2477	2477	2477	2351	2477		2351			
Max output (EEC net) / kW (PS)	100 (136)	100 (136)	100 (136)	81 (110)	81 (110)	81 (110)	81 (110)	94 (128)	131 (178)	100 (136)	100 (136)	94 (128)	97 (32)	100 (136)		97 (32)			
Max Torque (EEC net) Nm	324	324	324	200	200	200	200	200	400	324	324	240	202	324		202			
FUEL SYSTEM																			
Fuel Supply system	Electronic Common Rail Direct Injection								Electronic Common Rail Direct Injection					Electronic Controlled Injection -Multi Point Injection	Electronic Common Rail Direct Injection	Electronic Controlled Injection -Multi Point Injection			
Fuel tank capacity l	75								75					75	75	75			
TRANSMISSION																			
Type	5-Speed Automatic	5-Speed Manual				5-Speed Manual				5-Speed Manual			5-Speed Manual	5-Speed Manual	5-Speed Manual				
STEERING																			
Type	Rack and pinion power assisted								Rack and pinion power assisted					Rack and pinion power assisted					
Minimum turning radius m	5,9				5,7				5,9			5,7		5,9			5,7		
SUSPENSIONS																			
Front	Wishbone, coil springs								Wishbone, coil springs					Wishbone, coil springs					
Rear	Rigid, elliptic laef springs								Rigid, elliptic laef springs					Rigid, elliptic laef springs					
BRAKES																			
Front	16" Ventilated Disc				15" Ventilated Disc	16" Ventilated Disc	15" Ventilated Disc			16" Ventilated Disc			15" Ventilated Disc		16" Ventilated Disc			15" Ventilated Disc	
Rear	11,6" Leading and trailing drums				10" Leading and trailing drums	11,6" Leading and trailing drums	10" Leading and trailing drums			11,6" Leading and trailing drums			10" Leading and trailing drums		11,6" Leading and trailing drums			10" Leading and trailing drums	
Tires	245/70R16 (245/65R17)		205R16C		195R15C	205R16C	195R15C			245/70R16 (245/65R17)		205R16C	195R15C		205R16C		195R15C		

* Gulf cooperation council area